

Kelsan® Universal Crane Solution

Kelsan® SL (Solid Lubricant)
Kelsan® SFM (Solid Friction Modifier)

CRANE WHEEL FLANGES WEAR OUT FAST. HERE'S A FEW REASONS WHY:

- Buildings sinking
- Uneven braking/Acceleration torque
- Contaminantion
- Uneven rail alignments
- Uneven Loads

EASILY SOLVE THESE ISSUES WITH KELSAN'S UNIVERSAL CRANE SOLUTION:

Saving wheel flanges using lubrication is common. Kelsan takes this to the next level by offering solutions that incorporate a superior Flange Lubricant with a patented Tread Friction Modifier. These environmentally friendly products deliver incredible cost saving benefits.

KELSAN® SL BENEFITS

- Controls friction at a low level between the wheel flange and rail gauge
- Reduces wheel flange wear
- Reduces wheel/rail maintenance
- Consistent control of lubrication system wide



Before Kelsan SL/SFM System: Metal flakes from excessive wheel/rail flange wear.

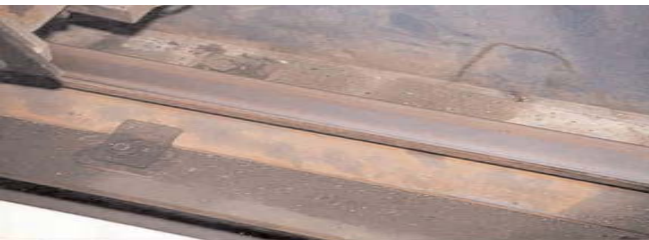

After Kelsan SL/SFM System: Metal flakes are gone, a sign that wheel/rail wear is significantly reduced.

KELSAN® SFM BENEFITS

- Controls friction at an intermediate level between the top of rail & wheel tread.
- Reduces "Crabbing"
- Reduces "Flanging"
- Reduces wheel/rail noise
- Reduces wheel/slip and spin
- Reduces lateral trolley movement

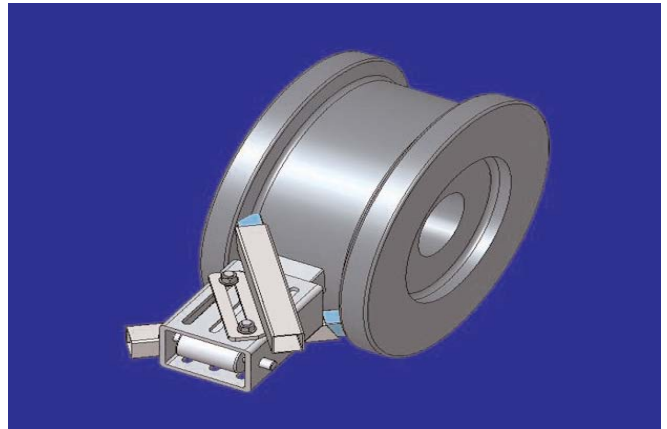

Application: Kelsan SL/SFM system applied to both wheel flanges and tread.

KELSAN® SL

- Dry solid environmentally friendly lubricant
- Low coefficient of friction
- Provides a protective layer between metal surfaces
- Does not attract contaminants
- Decrease the risk of derailments

KELSAN® SFM

- Dry solid environmentally friendly friction modifier
- Intermediate coefficient of friction
- Provides unsurpassed friction control between metal surfaces
- Acts as a lubricant in rolling conditions (friction level 0.17) and a friction enhancer in slide conditions (friction level 0.35)
- Does not impair braking or traction
- Does not attract contaminants

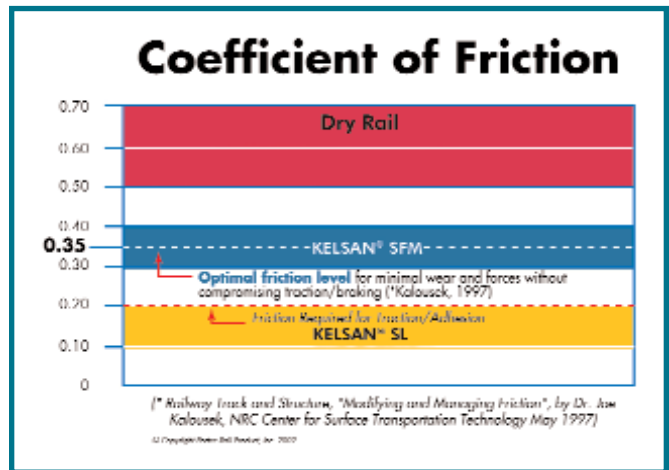
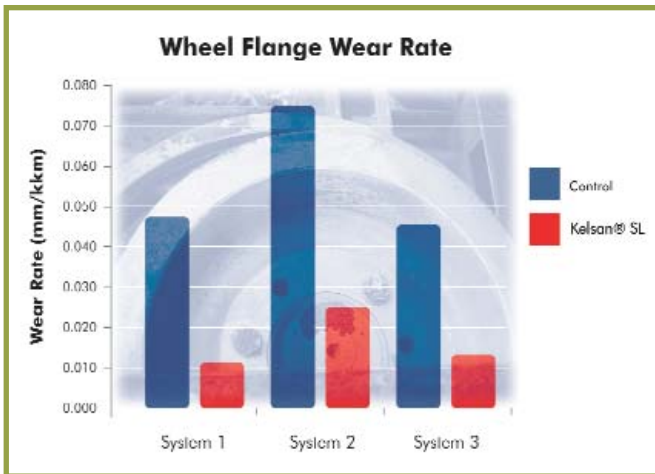

WWW.KELSAN.COM

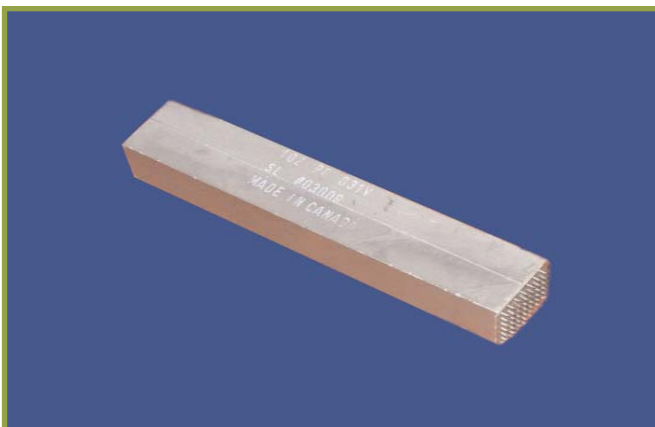

Kelsan SL Solid Lubricant Stick

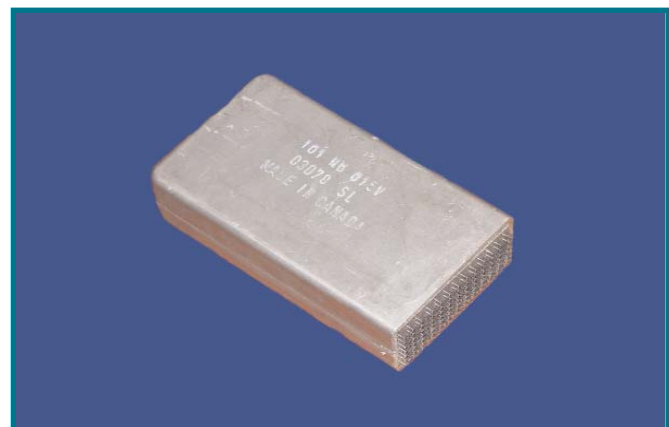

Kelsan SFM Solid Friction Modifier Stick

KB Industrial Sales • Authorized Kelsan Agent - North American Crane Industry
 2528 Hyannis Drive • North Vancouver • B.C. • V7H 2E8 • Canada
 Tel: 604.929-5939 • Fax: 604.929-5939 • e-mail: kenbr1@attglobal.net

